



An original shape where looks and ergonomics meet. The synthesis of Patricia Urquiola's constant research into expression and Molteni & C's typical aptitude for experimentation. *Night & Day* stands out for its young, minimal lines and the strong, decisive headboard which gives personality and looks to the bedroom. *Night & Day* is a large and comfortable bed. It has a padded headboard that can be tilted to several positions to facilitate those sitting up to read or watch TV. Totally removable upholstery in both the fabric and leather versions, for easy maintenance. *Night & Day* is ideal for contemporary and classic environments thanks to the vast range of Molteni & C fabrics and leathers.



Patricia Urquiola a legend of Italian design, cultivated and elegant, with an extrovert Spanish temperament. This is the secret to Patricia Urquiola's success. A designer who has given new meaning to living, classic and informal, intimate and versatile. Like her chairs and armchairs, soft and undulating. Patricia Urquiola was born in Oviedo, Spain. After studying at the Facultad de Arquitectura in Madrid, she graduated in 1989 from the Milan Politecnico under the supervision of Achille Castiglioni. In 1991 she worked on the De Padova product development, where she met Vico Magistretti. In 1993 she opened a studio with partners M. de Rienzo and E. Ramerino developing interior, showroom and restaurant design. In 2001 she opened her own studio, taught seminars at the Domus Academy Designing Exhibition in Australia and started acting as a member of the jury in important international competitions such as the 19th CDIM Award. She still works as a designer for large companies, creating products able to catch the public's attention. "I understand how much my design pleases the public by how many people touch it," she says. "I need people to approach it, want to touch it. I like the object to inspire active curiosity." Philippe Daverio is right when he says that tomorrow's design is female, Spanish and colourist. Patricia Urquiola has created several designs and collections for Molteni & C. Glove is a seating family completely upholstered in microfibre, fabric or leather "worn" by a metal structure. Clip is an original double bed. The table Diamond won the Red Dot Award as best product for 2005.

■ Finishes

Cover (fully removable)

fabric
leather

Metal legs

black

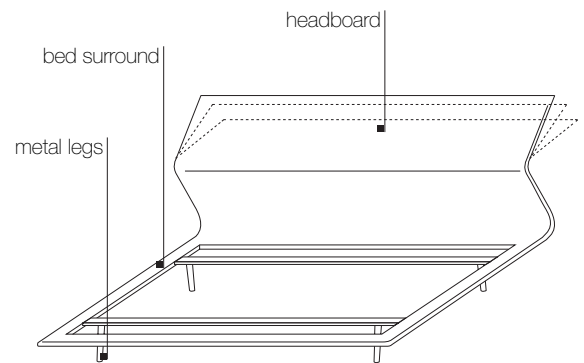

■ Types

bed taking the fixed double slatted base
or 2 single slatted bases

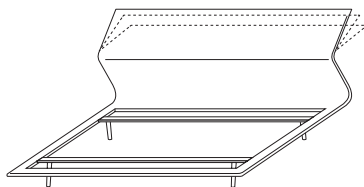

NLE16

NLE17

NLE18

■ Dimensions

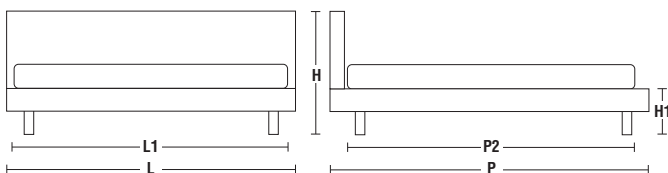

outer dimensions

L	width	1780 70"	1880 74"	1980 78"
P	length	2270 89 3/8"	2370 93 1/4"	
H	height	950 37 3/8"		
H1	bed base height	240 9 1/2"		

inner dimensions

L1	width (mattress)	1600 63"	1700 66 7/8"	1800 70 7/8"
P2	length (mattress)	2000 78 3/4"	2100 82 3/4"	

Note: depth **P** and height **H** vary depending on the headboard inclination

On request the mm 2100 depth (82 3/4") (inner dimension)