



*Pass* is a versatile system for the living-room. Storage units, modular shelves, tops and chests of drawers to create traditional modules. Or new compositions, instead, forming an interplay of masses and voids. To partition space without splitting it up. The finishes, too, match different tastes and needs. Wood, mat and glossy lacquer for shelves and back panels. Chests of drawers with polished wooden or glass front elements, and tops of marble. Thanks to its equipped base units, *Pass* can house all the components of HI-FI audio systems: CD and DVD readers, amplifiers, iPod. Columns, stationary and adjustable TV set-bearing panels, storage units equipped with a special front permeable to the infrared

beams of the remote control. No wiring is left exposed. *Pass* storage units can be placed on the floor, used as wall units or placed one on top of the other. To create countless and easy combinations. *Pass* includes desks and tops thanks to which it can serve as a practical home office.

*Pass* includes many functions also in the bedroom area. Comfortable benches where to lay down things and place the TV set. Storage units and chests of drawers in different finishes. Plenty of room and a rational design to meet any need.



**Luca Meda** is an important name in the history of Italian industry, and has contributed to the design culture of the Molteni Group with great passion. An example of harmonic partnership between creativity and business, art and industry. Almost a paradox for a designer who loves design and used the pencil more than any other instrument to describe and reinvent reality. Luca Meda was born in Chiavari by chance – his family spent their holidays there. He grew up and studied in Milan, graduating from the Brera Art School. He loved the centre of Milan and its urban landscape. Its monuments, its anonymous houses, the near invisible interiors and the good quality objects inside them all contributed to his emotional growth and development. He then studied in Germany, at the Hochschule für Gestaltung in Ulm, one of the most prestigious international design schools, founded in 1954 by Inge Scholl-Aicher and directed by Max Bill. His encounter with Aldo Rossi is a crucial moment. Together they opened a studio and took part in numerous competitions, such as that for the Contemporary History Museum in Milan. Since the late seventies, Luca Meda has been working on design and mass produced series. His main partnership is with the Molteni Group. His designs for Molteni & C. include a series of furnishings which are now considered icons, such as the Piroascafo bookcase designed with Aldo Rossi, the *Zim* and *Ho* chairs, the armchairs *Hi-Cove* and *Vivette* and the *505* programme. Meda has also created furnishing systems such as *Pass*, which allows the client to match simple and elegant open containers, sideboards, bookcases, benches and shelves, and *909*, a flexible system of chests of drawers.

### ■ Elements

- 1 - TV panel
- 2 - top
- 3 - Hi-Fi base unit
- 4 - suspended storage units
- 5 - partitions
- 6 - shelves
- 7 - sliding door

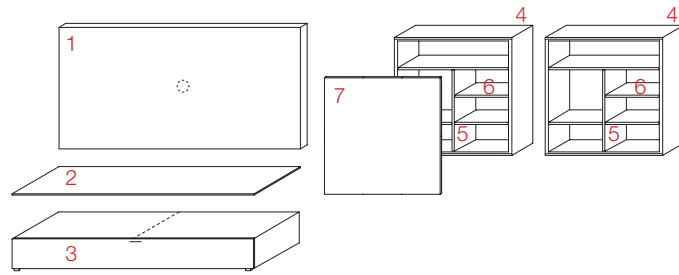

- 1 - benches with open compartment
- 2 - suspended storage units
- 3 - partitions
- 4 - flap doors

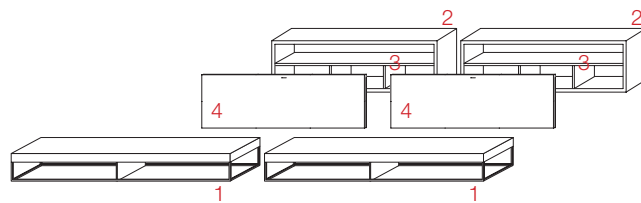

- 1 - drawer units structures
- 2 - top
- 3 - wooden drawers
- 4 - Hi-Fi drawer
- 5 - desk
- 6 - open wall unit

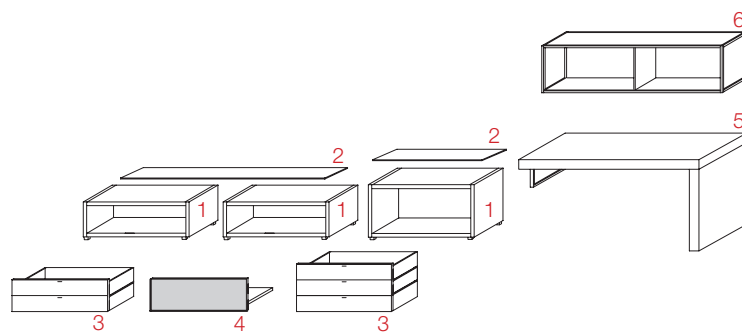

- 1 - floor standing
- 2 - partition
- 3 - top
- 4 - hinged door
- 5 - upper shelf
- 6 - central shelves
- 7 - lower shelf
- 8 - backs
- 9 - suspended column
- 10 - partitions
- 11 - hinged door

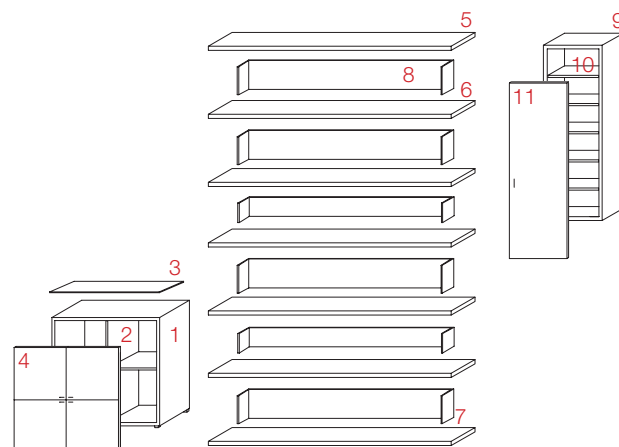

### Finishes

matt lacquer colours    glossy lacquer colours    woods    coloured glass    coloured etched glass    semi-transparent glass    etched glass    shiny aluminium    marbles

#### components

##### storage units/drawer units/column with door

|  |       |  |  |  |  |  |  |  |  |
|--|-------|--|--|--|--|--|--|--|--|
| structure  |       |  |  |  |  |  |  |  |  |
| partitions   |       |  |  |  |  |  |  |  |  |
| wooden doors, pressure-opening or sliding              |       |  |  |  |  |  |  |  |  |
| glass doors, pressure-opening/sliding doors/flap doors | trim  |  |  |  |  |  |  |  |  |
|  | glass |  |  |  |  |  |  |  |  |
| pressure-opening wooden drawer fronts                  |       |  |  |  |  |  |  |  |  |
| wooden door with handle / sliding doors                |       |  |  |  |  |  |  |  |  |
| wooden drawer fronts with handles                      |       |  |  |  |  |  |  |  |  |
| glass/hi-fi drawer fronts/sliding doors                | trim  |  |  |  |  |  |  |  |  |
|  | glass |  |  |  |  |  |  |  |  |
| tops   |       |  |  |  |  |  |  |  |  |

##### Hi-Fi base units D 655 - 25 3/4"

|  |       |  |  |  |  |  |  |  |  |
|--|-------|--|--|--|--|--|--|--|--|
| structure  |       |  |  |  |  |  |  |  |  |
| wooden fronts flap door or pressure-opening drawer |       |  |  |  |  |  |  |  |  |
| glass fronts flap door or pressure-opening drawer  | trim  |  |  |  |  |  |  |  |  |
|  | glass |  |  |  |  |  |  |  |  |
| wooden fronts flap door or drawer with handle      |       |  |  |  |  |  |  |  |  |
| glass fronts flap door or drawer with handle       | trim  |  |  |  |  |  |  |  |  |
|  | glass |  |  |  |  |  |  |  |  |
| tops   |       |  |  |  |  |  |  |  |  |

##### Hi-Fi benches

|              |       |  |  |  |  |  |  |  |  |
|--------------|-------|--|--|--|--|--|--|--|--|
| structure    |       |  |  |  |  |  |  |  |  |
| glass fronts | trim  |  |  |  |  |  |  |  |  |
|              | glass |  |  |  |  |  |  |  |  |

##### bench th. 80 - 3 1/8" with feet

|      |  |  |  |  |  |  |  |  |  |
|------|--|--|--|--|--|--|--|--|--|
| tops |  |  |  |  |  |  |  |  |  |
| feet |  |  |  |  |  |  |  |  |  |

##### tv panels

|       |  |  |  |  |  |  |  |  |  |
|-------|--|--|--|--|--|--|--|--|--|
| panel |  |  |  |  |  |  |  |  |  |
|-------|--|--|--|--|--|--|--|--|--|

##### modular shelves

|         |  |  |  |  |  |  |  |  |  |
|---------|--|--|--|--|--|--|--|--|--|
| shelves |  |  |  |  |  |  |  |  |  |
| back    |  |  |  |  |  |  |  |  |  |

##### wall units

|           |  |  |  |  |  |  |  |  |  |
|-----------|--|--|--|--|--|--|--|--|--|
| structure |  |  |  |  |  |  |  |  |  |
| top       |  |  |  |  |  |  |  |  |  |
| back      |  |  |  |  |  |  |  |  |  |
| flap door |  |  |  |  |  |  |  |  |  |

##### desk

|                    |  |  |  |  |  |  |  |  |  |
|--------------------|--|--|--|--|--|--|--|--|--|
| wooden top and leg |  |  |  |  |  |  |  |  |  |
| metal leg          |  |  |  |  |  |  |  |  |  |

#### colours

**N.B**  
Coloured etched glass comes with shiny aluminium trim. The name of semitransparent glass is understood to be the shade of reference

#### Matt lacquer

BC chalk white    RT venetian red  
AV ivory    BO bordeaux  
PE pearl    AM amber  
AB alabaster    MZ aubergine  
DN dune    RC powder pink  
PL platinum    NL hazelnut  
PB lead    AT anthracite  
MK moka  
NE black

#### Glossy lacquer

BC chalk white    AM amber  
PE pearl    MZ aubergine  
DN dune    AT anthracite  
PL platinum  
PB lead  
MK moka  
NE black  
RT venetian red  
BO bordeaux

#### Woods

CN american walnut  
WE wengé  
RS dark oak  
RG grey oak

#### Coloured glass / Glossy lacquer glass door trim

BC chalk white    AM amber  
PE pearl    MZ aubergine  
DN dune    AT anthracite  
PL platinum  
PB lead  
MK moka  
NE black  
RT venetian red  
BO bordeaux

#### Coloured etched glass

BC chalk white    AM amber  
PE pearl    MZ aubergine  
DN dune    RC powder pink  
PL platinum    NL hazelnut  
PB lead    AT anthracite  
MK moka  
NE black  
RT venetian red  
BO bordeaux

#### Semitransparent glass

NE black (fumé)  
BC chalk white  
AM amber  
MZ aubergine  
SGR stopsol grey

#### Marbles

GNA absolute black  
MCB calacatta

## ■ Handles

### Hinged doors and fronts, sliding door

matt lacquered  
glossy lacquered



Pressure-opening door and front

wood



Pressure-opening door and front

coloured glass, semitransparent  
glass, shiny aluminium or glossy  
lacquered frame

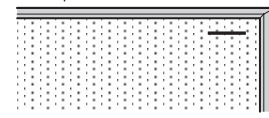

Pressure-opening door

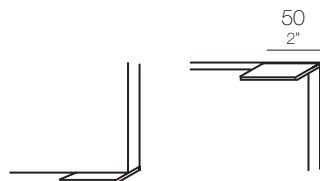

Door with handle

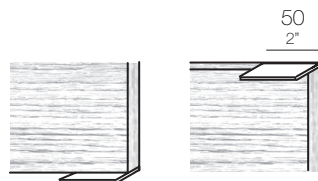

Door with handle

### Sliding door and glass / Hi-Fi drawer front

coloured glass, semitransparent  
glass, shiny chrome frame

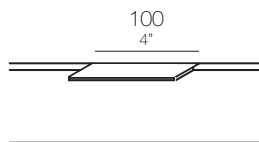

Front with handle

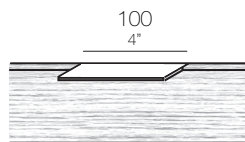

Front with handle

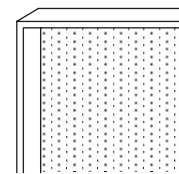

Door and front

## ■ Compatibility table for sliding doors

Suspended storage units d. 300 cm  
Storage units for standing d. 460 cm

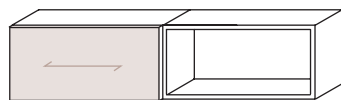

w. 1920 cm (2 x 960)  
h. 480 cm

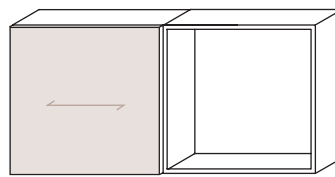

w. 1920 cm (2 x 960)  
h. 960 cm

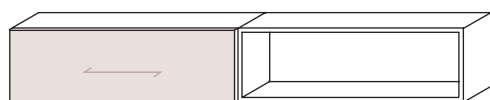

w. 2880 cm (2 x 1440)  
h. 480 cm

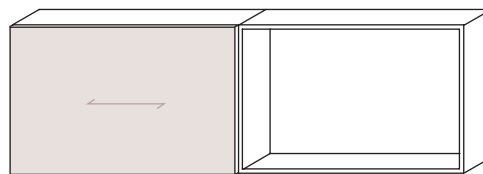

w. 2880 cm (2 x 1440)  
h. 960 cm

### Hi-Fi base units

Hi-Fi base units D 655 (25 3/4")

Hi-Fi base units are available in two heights (mm 270 and 510 - 10 5/8" and 20") and in three widths (mm 960-1440-1920 - 37 3/4"-56 3/4"- 75 5/8") with the option of inserting drawers or flap doors.

The fronts are available with both pressure-opening and with handle.

The top of the structure can be pulled forward to allow connection between various AV equipment or for inspection.

Tops listed on page 114 must be used with Hi-Fi base units.

The Hi-Fi base units come with a soft rubber profile at the back to allow wiring to pass when positioned against a wall.

No alternatives to the Hi-Fi bases indicated in the price list are available.

Standard version with fully extractable cushioned runners.

**No open compositions possible.**

**The Hi-Fi bases W 1440 mm (56 3/4") and 1920 mm (75 5/8") with pressure opening always come with electrically wired drawer.**

**Only the semi-transparent glass finish allows remote control signals to pass through the drawer front when closed.**

