



*Sequence*, Patricia Urquiola's new modular bookcase, is an example of domestic architecture which draws its inspiration from modern composition styles featured in many contemporary buildings. *Sequence* is modular and therefore flexible, bringing the concept of symmetry and asymmetry into the domestic setting, an innovative concept for this type of product. An airy structure without side partitions, and featuring a thick beam element along which run sliding doors in various materials such as carved steel in various finishes, essences, surfaces lacquered in original colours or glass etched with high impact geometrical designs. There are two types of partition, plain or carved

in U shape, to place freely on the shelves and created symmetrical or asymmetrical sequences. This gives greater freedom in what can be placed on the bookcase.

*Sequence* is avant-garde in both design and technology. Structural shelving and partitions are covered with lacquered aluminium to give strength and stability to the whole bookcase, even in larger compositions. *Sequence* is available in various compositions, differing in both height and width, so as to create various storage solutions of high impact and functional discipline.



**Patricia Urquiola** a legend of Italian design, cultivated and elegant, with an extrovert Spanish temperament. This is the secret to Patricia Urquiola's success. A designer who has given new meaning to living, classic and informal, intimate and versatile. Like her chairs and armchairs, soft and undulating. Patricia Urquiola was born in Oviedo, Spain. After studying at the Facultad de Arquitectura in Madrid, she graduated in 1989 from the Milan Politecnico under the supervision of Achille Castiglioni. In 1991 she worked on the De Padova product development, where she met Vico Magistretti. In 1993 she opened a studio with partners M. de Rienzo and E. Ramerino developing interior, showroom and restaurant design. In 2001 she opened her own studio, taught seminars at the Domus Academy Designing Exhibition in Australia and started acting as a member of the jury in important international competitions such as the 19th CDIM Award. She still works as a designer for large companies, creating products able to catch the public's attention. "I understand how much my design pleases the public by how many people touch it," she says. "I need people to approach it, want to touch it. I like the object to inspire active curiosity." Philippe Daverio is right when he says that tomorrow's design is female, Spanish and colourist. Patricia Urquiola has created several designs and collections for Molteni&C. Glove is a seating family completely upholstered in microfibre, fabric or leather "worn" by a metal structure. Clip is an original double bed. The table Diamond won the Red Dot Award as best product for 2005.

### ■ Finishes

**Structure, back, shelves, partitions:** matt lacquer colours: chalk white, black, amber, powder pink, hazelnut, black with american walnut edge

**cut work partitions:** matt lacquer colours: chalk white, black, amber, powder pink, hazelnut

**Doors - matt lacquer colours:** chalk white, black, amber, powder pink, hazelnut

**Doors - wood:** american walnut

**Doors - metal mesh lacquered in the colours:** chalk white, black, amber, powder pink, hazelnut

**Doors - glass:** black serigraphed stopsol

### ■ Modular items - bookcases d. 400 mm - 15 3/4"

Available in 5 widths (w. 1208 - 1808 - 2408 - 2708 - 3008)  
and 3 heights (h. 1412 - 2006 - 2358 for d. 400)

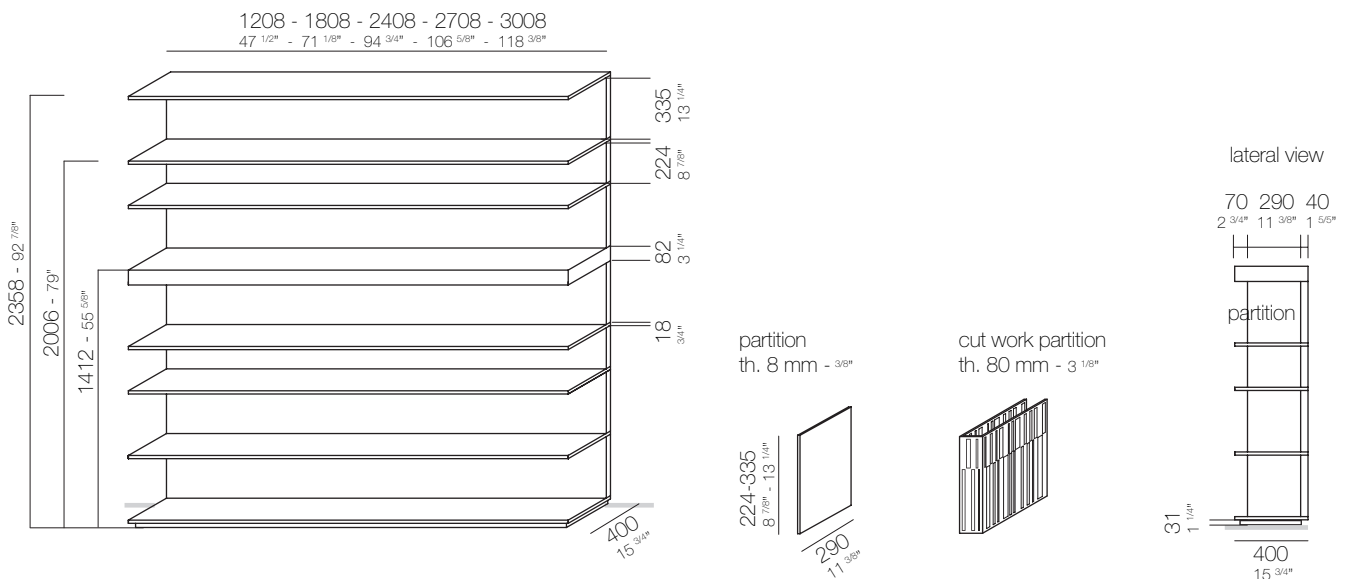

### ■ Modular items - bookcases d. 530 mm - 20 7/8"

Available in 5 widths (w. 1208 - 1808 - 2408 - 2708 - 3008)  
and 3 heights (h. 465 e 707 for d. 530)

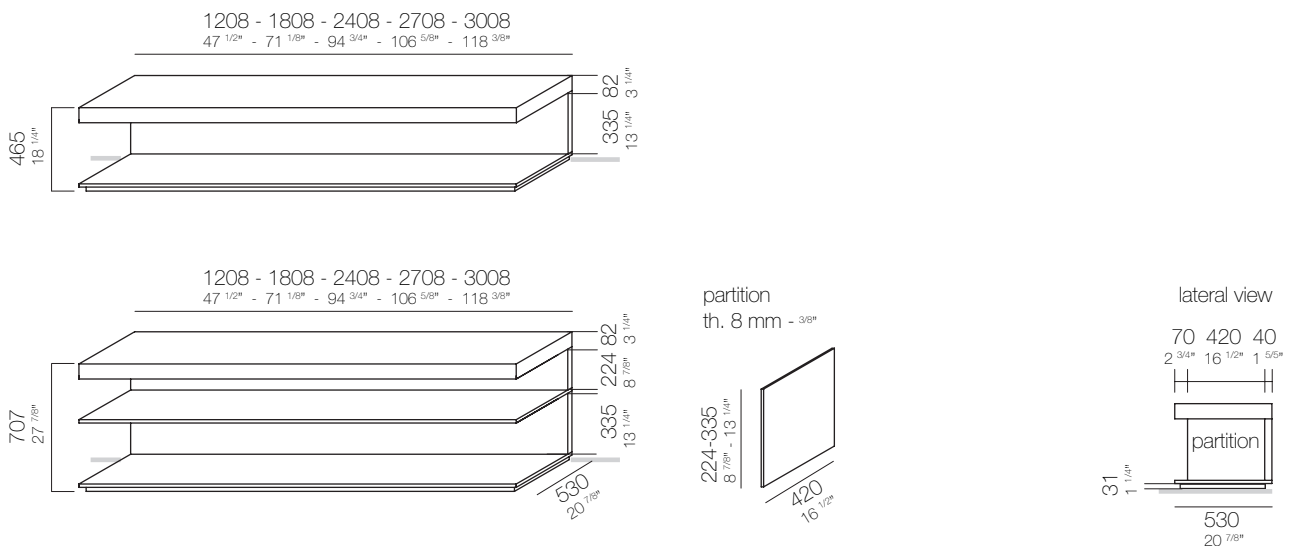

### ■ Example positioning of partitions

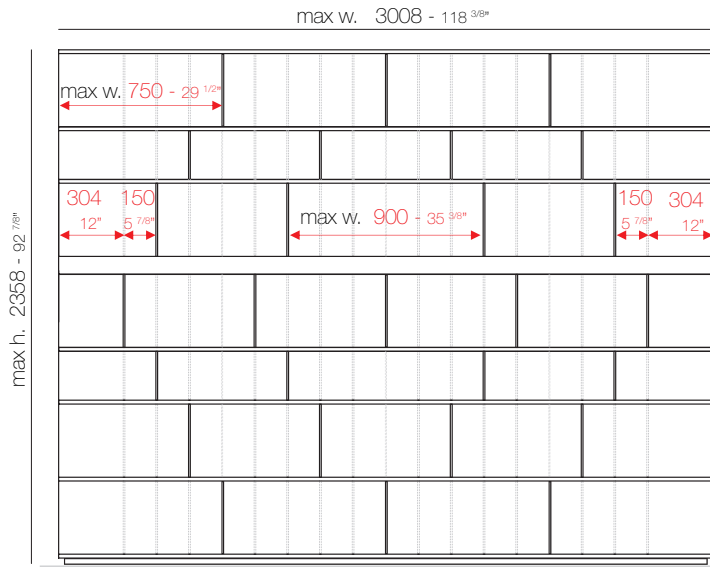

The horizontal grid for single units is divided every 150 mm starting at 304 mm.

The partitions can be positioned inside the grid respecting:

- max width 750 mm for external units;
- max width 900 mm for centre units.

The abovementioned rule also applies to cut works partitions.

Example positioning of lighting partitions

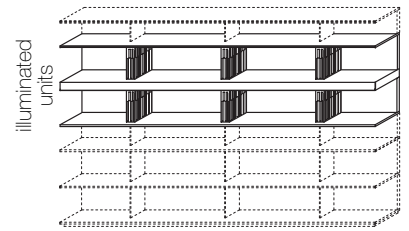

### ■ Sliding doors

The compositions are available open or with sliding doors. In the latter case the 82 mm th. shelf and the 18 mm th. shelf or shelves come fitted with runners;

It is not possible to put 2 sliding doors next to each other;

The doors w. 1208 h. 1337 are not available in matt lacquer colours and in american walnut;

For door composition see the following schemes.

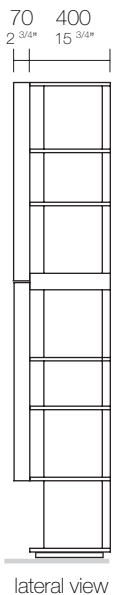
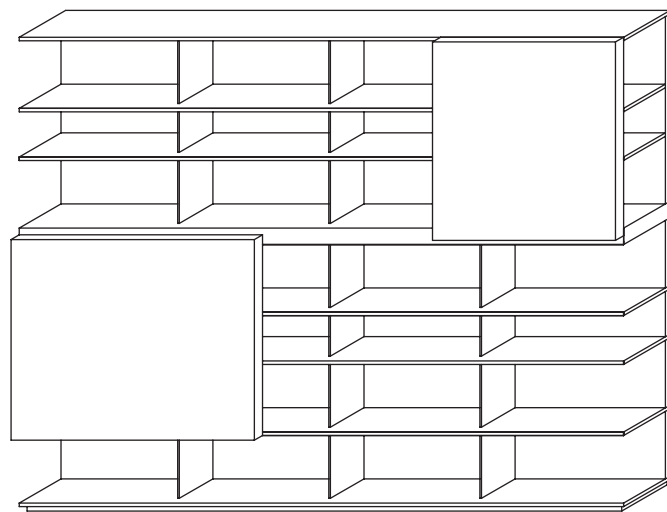

upper doors  
w. 908 th. 70 mm  
w. 35 3/4" - th. 2 3/4"

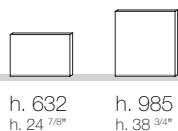

lower doors  
w. 908 th. 70 mm  
w. 35 3/4" - th. 2 3/4"

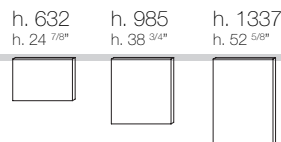

upper doors  
w. 1208 th. 70 mm  
w. 47 1/2" - th. 2 3/4"

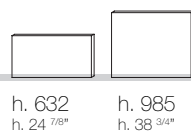

lower doors  
w. 1208 th. 70 mm  
w. 47 1/2" - th. 2 3/4"

